

A0721-108 Monitor Well Manhole

Guide Specification:

1. Meets AASHTO H20 wheel loading
2. Cast-in identification triangle in accordance with API recommendations
3. Bolt-down, water-tight lid
4. Painted cast iron lid and rim
5. 20 gauge galvanized steel skirt
6. 3/8" x 1" bolt with 9/16" hex head

Weight: 13.2 lbs.

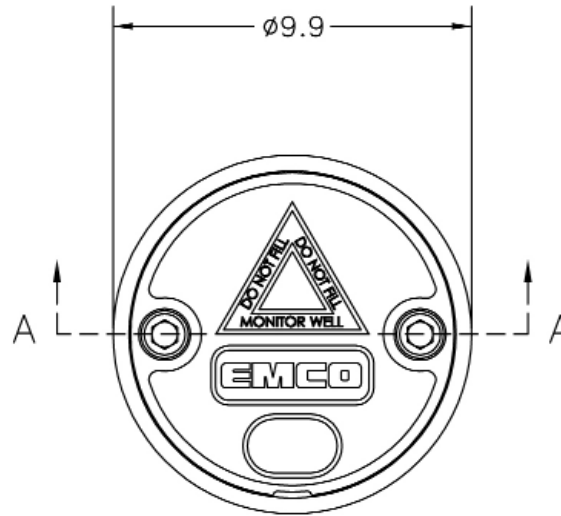

TOP VIEW

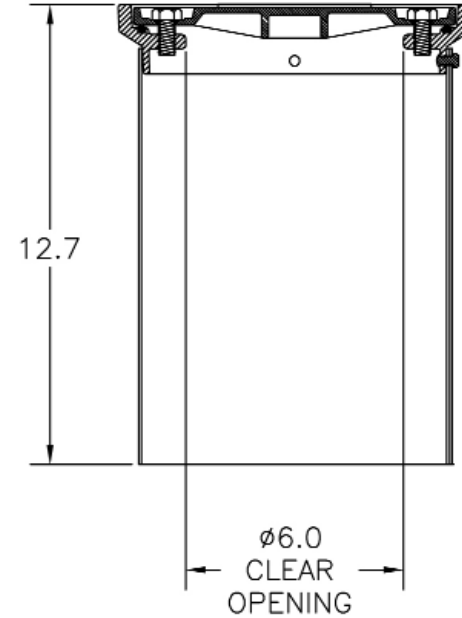

SECTION A-A

EMCO® WHEATON RETAIL		EMCO WHEATON RETAIL CORPORATION 2300 INDUSTRIAL PARK DRIVE WILSON, N.C. 27893					
DO NOT SCALE DRAWING—WORK TO DIMENSIONS SHOWN DIMENSIONS ARE IN INCHES (DIMENSIONS IN BRACKETS ARE IN MILLIMETERS)				A	MARKETING	04/05/11	JBV
UNLESS OTHERWISE SPECIFIED				SYM		REVISIONS	
DECIMALS ANGLES .X ± .030 .XX ± .015 .XXX ± .005 ± 1° CASTING TOLERANCES TO INDUSTRY STANDARDS MACHINED SURFACES 125 RMS REMOVE ALL BURRS				DRAWN BY JBV		DATE 04/05/11	
THE INFORMATION AND DESIGN DISCLOSED BY AND THE COPYRIGHT IN THIS DRAWING ARE THE PROPERTY OF EMCO WHEATON RETAIL CORP. AND CANNOT BE USED WITHOUT WRITTEN PERMISSION.				CHECKED BY		DATE	
				APPROVED BY		DATE	
				SCALE NTS		WEIGHT	
				MATERIAL		CASTING NUMBER	
				PART NAME MONITORING WELL MANHOLE, 8" x 12" HIGH WITH GALVANIZED STEEL SKIRT			
				SIZE		DRAWING NUMBER.	
				A		A0721-108	
						REV. A	