

12" x 8" Aircraft Rated Manhole (Cast Iron Construction)

Specifications

12"x8" Cast Iron
2 Bolt Construction
Aircraft Rated (200,000 lbf)
Weight 85 lbs

Item#: MM12X8AR

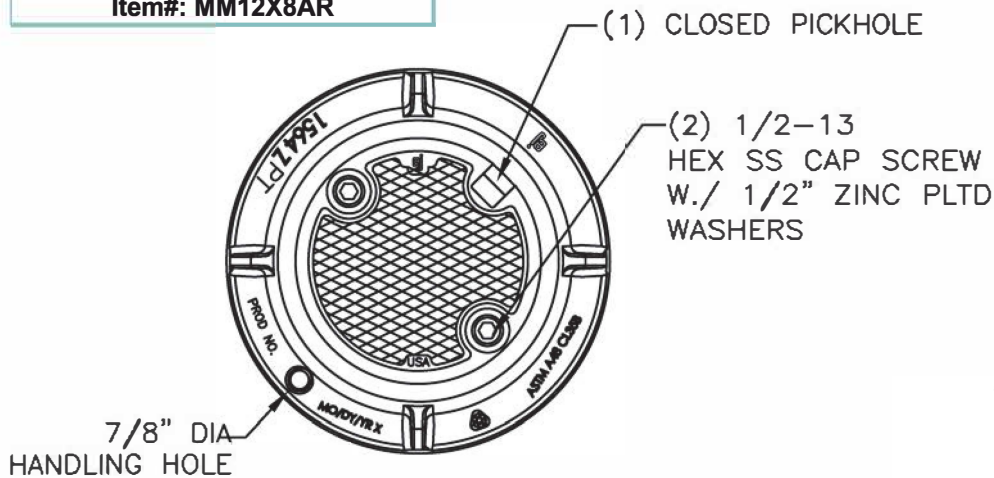

PLAN VIEW

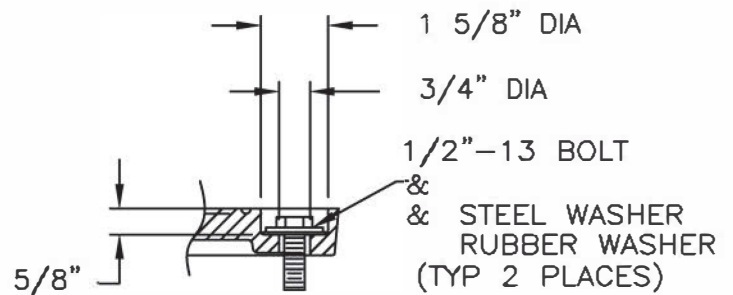

BOLTHOLE DETAIL

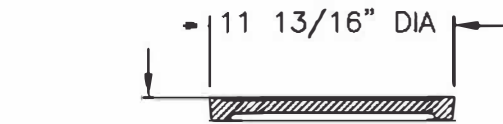

1 1/8" COVER SECTION

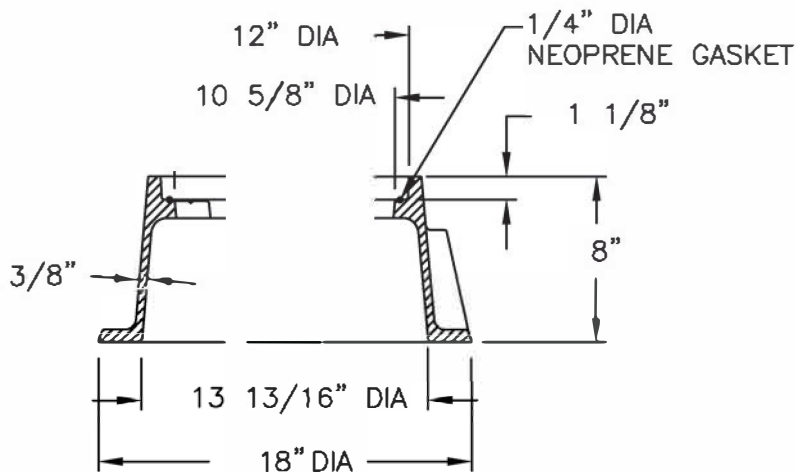

FRAME SECTION



ECT Manufacturing, Inc.
11 Black Forest Rd | Hamilton, NJ | 08691
t. 609.631.8939 | 888.240.4328 | f. 609.631.0993
www.ectmfg.com